

△ "X" IS GREATER THAN OR EQUAL TO 6"
AND LESS THEN OR EQUAL TO 18"

TO BE USED FOR LOT DIFFERENCE LESS THAN 18"

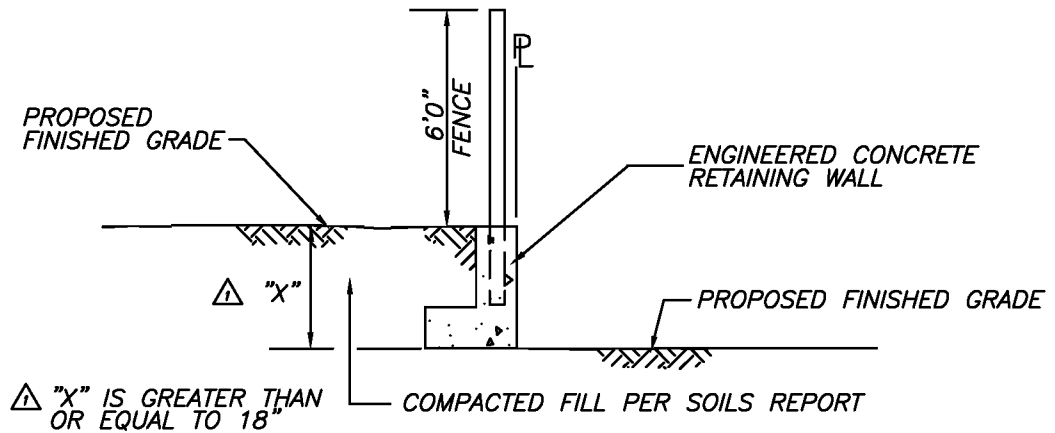

△ "X" IS GREATER THAN
OR EQUAL TO 18"

TO BE USED FOR LOT DIFFERENCE OF 18" OR GREATER

NOTES:

1. DETAILS AND CALCULATIONS FOR THE CONCRETE RETAINING WALL SHALL BE SUBMITTED TO THE CITY OF RIPON ENGINEERING DEPARTMENT FOR APPROVAL.

NO.	REVISED	BY	Property Line Retaining Wall	APPROVED
△	1-2003	MJM		 CITY ENGINEER RCE-28191
DRAWN BY: TP				DATE: 2-2-99
CHECKED BY: DJR			CITY OF RIPON	STANDARD NO. M-13
SCALE: NONE				