

## EXPANSION JOINT

4'-2" WHEN PARALLEL WITH STREET  
6'-2" WHEN PERPENDICULAR TO STREET

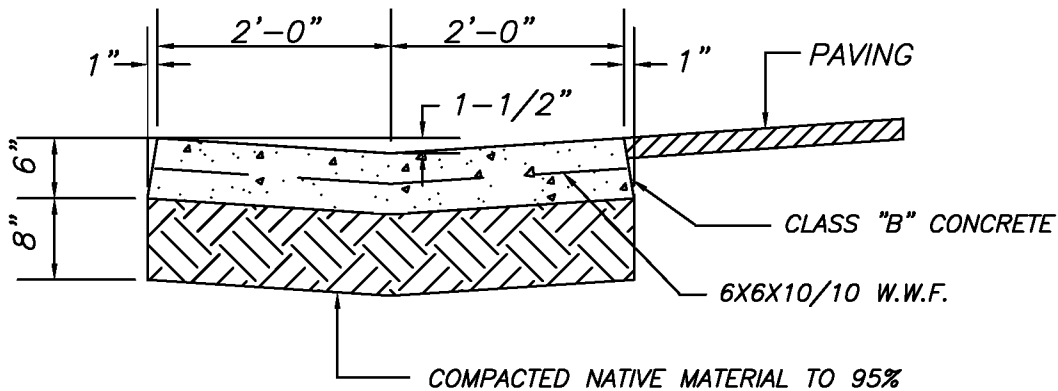

## CONCRETE VALLEY GUTTER

### NOTES

1. CONSTRUCT EXPANSION JOINTS AT 200 FEET CENTER TO CENTER, AT BEGINNING & ENDS OF CURBS, EACH SIDE OF CATCHBASINS AND OTHER FIXED OBJECTS.
2. CONCRETE VALLEY GUTTER TO BE USED ONLY WITH SPECIFIC APPROVAL OF THE CITY ENGINEER.
3. SEE NOTES ON CONCRETE CONSTRUCTION C.O.R. STDS.
4. MIN. FALL OF GUTTER SHALL BE SET BY CITY ENGINEER.

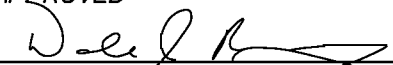
NO.	REVISED	BY	<b>Typical Expansion Joint and Valley Gutter</b>	APPROVED
△	1-2003	MJM		 CITY ENGINEER RCE-28191
DRAWN BY: MCP				DATE: 2-2-99
CHECKED BY: DJR			<b>CITY OF RIPON</b>	STANDARD NO. <b>M-19</b>
SCALE: NONE				